

**PLAN - BRICK PAVER WALKWAY**

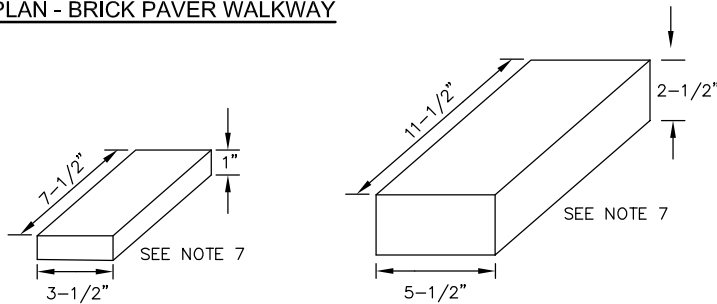

**SIDEWALK PAVER**

**BORDER PAVER**

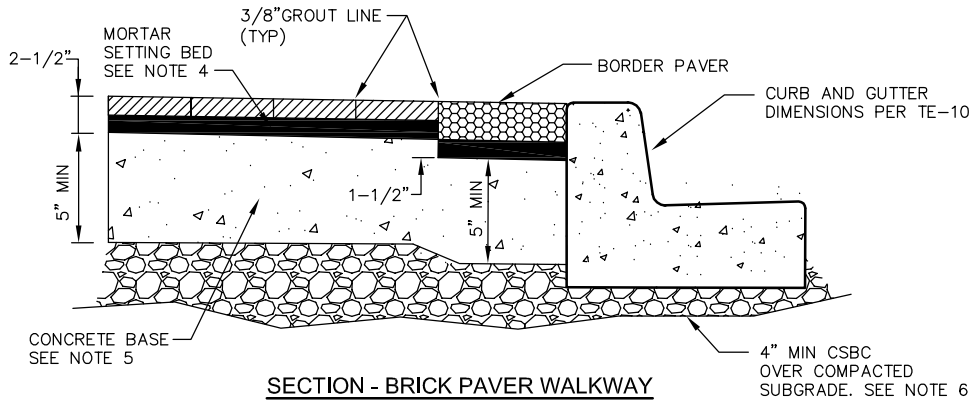

**SECTION - BRICK PAVER WALKWAY**

**NOTES:**

1. SIDEWALK DIMENSIONS SHALL BE PER THE APPROVED PLANS.
2. 3/8" FULL DEPTH EXPANSION JOINT EVERY 10' OF WALKWAY LENGTH. EXPANSION JOINT SHALL RUN FROM BACK OF WALK TO FRONT OF CONCRETE GUTTER; AT FULL DEPTH FROM TOP OF PAVERS TO CONCRETE BASE. JOINT MATERIAL AND SEAL PER MANUFACTURER'S SPECIFICATIONS.
3. SEE STD. DWG. SW-100-1 FOR CURB AND GUTTER DIMENSIONS AND SPECIFICATIONS.
4. PLACE 1/16 INCH OR LESS SLURRY BOND COAT TO CONCRETE BASE IMMEDIATELY PRIOR TO INSTALLING MORTAR BED SETTING. MORTAR/ SLURRY SHALL BE INSTALLED PER MANUFACTURER'S SPECIFICATIONS.
5. ADDITIONAL DEPTH MAY BE REQUIRED AT THE DISCRETION OF THE ENGINEER. CONCRETE SHALL BE AIR ENTRAINED CLASS 3000 PER WSDOT STANDARD SPECIFICATIONS. REBAR MAY BE REQUIRED AT THE DISCRETION OF THE ENGINEER.
6. CSTC THICKNESS MAY BE INCREASED AT THE DISCRETION OF THE ENGINEER. ENGINEER TO APPROVE SUBGRADE MATERIAL & COMPACTION PRIOR TO CONCRETE BASE INSTALLATION.
7. PAVERS SHALL BE MUTUAL MATERIALS CHESTNUT WITH WIRE CUT SURFACE FINISH. APPLY THIN SLURRY BOND COAT WITH TROWEL ON THE BOTTOM OF PAVER PRIOR TO INSTALLING IN MORTAR SETTING BED.
8. ALL VAULT/UTILITY/ JUNCTION BOX LIDS LOCATED IN THE WALKWAY SHALL HAVE A NON-SKID SURFACE, SLIPNOT GRIP PLATE GRADE 3 SURFACE, IKG INDUSTRIES MEBAC #1 OR APPROVED EQUAL AND ABLE TO BEAR HL-93 DESIGN VEHICLE WHEEL LOADING. MIN. 2" CONCRETE COLLAR REQUIRED.
9. ALL PAVERS AND GROUT LINES SHALL BE WATERSEALED PER MANUFACTURER'S SPECIFICATIONS.



**BRICK PAVER INSTALLATION FOR OLD BELLEVUE DISTRICT**

DRAWING NUMBER	DT-160-1
SCALE	NONE
REVISION DATE	12/17
DEPARTMENT	TRANS