

**HIGHWAY-RAIL GRADE CROSSING
PAVEMENT MARKINGS**

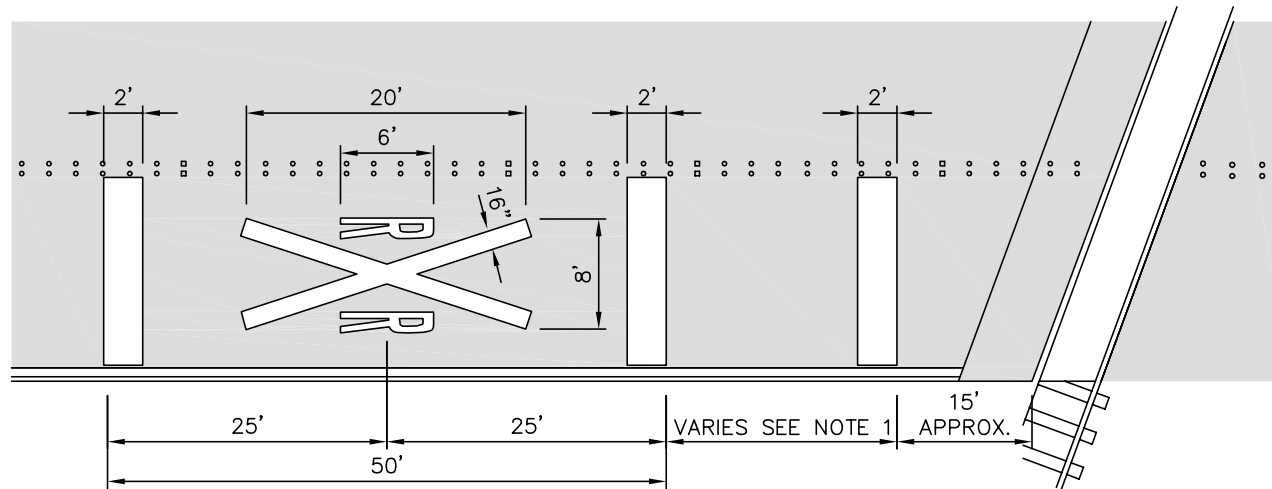

**ALTERNATE "WIDE" PAVEMENT
MARKINGS**

NOTES:

1. FOR DISTANCE, SEE CHAPTER 2C, TABLE 2C-4 OF THE LATEST REVISION OF THE MUTCD.
2. MATERIAL SHALL BE THERMOPLASTIC UNLESS OTHERWISE APPROVED BY THE ENGINEER.
3. USE ALTERNATE "WIDE" MARKINGS ONLY WHEN APPROVED BY THE ENGINEER.



**HIGHWAY – RAIL GRADE CROSSING
PAVEMENT MARKINGS**

DRAWING NUMBER	CH-180-1
SCALE	NONE
REVISION DATE	12/16
DEPARTMENT	TRANS