

**DRIVEWAY APPROACH DETAIL**

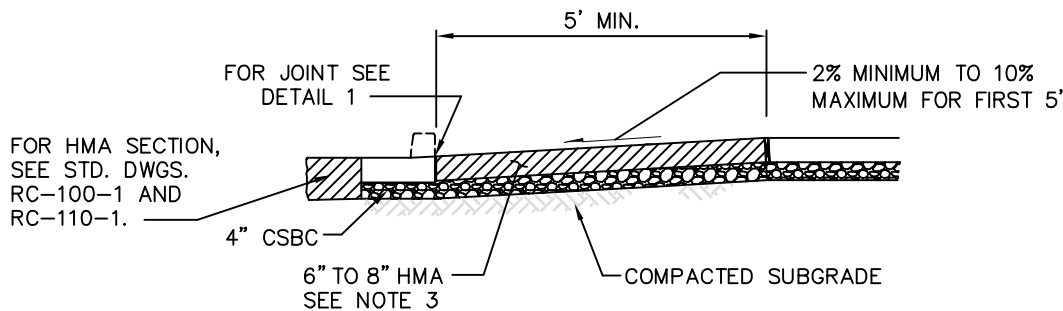

**SECTION A-A**

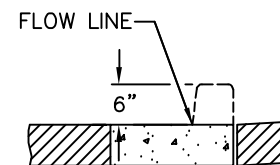

**DETAIL 1**

**NOTES:**

1. SEE SECTION 3.5 OF THE DESIGN MANUAL FOR DRIVEWAY WIDTH, DESIGN DETAILS, AND GRADING REQUIREMENTS.
2. AT SAWCUT, TACK COAT EXISTING SURFACES WITH CSS-1 AND SEAL IN ACCORDANCE WITH WSDOT STD. SPEC. SECTION 5-03.
3. DRIVEWAY APPROACH TO BE 6" TO 8" HMA CLASS ½" PG 58H-22 ASPHALT IN 2" LIFTS FOR MINIMUM 5' BEHIND CURB.
4. HOT MIX ASPHALT OR CONCRETE TO BE PLACED OVER COMPACTED SUBGRADE AND 4" OF CSBC COMPACTED TO 95%.
5. TYPICAL EDGE RADIUS:
 

COMMERCIAL	15'
RESIDENTIAL, ARTERIAL STREET	10'
RESIDENTIAL, LOCAL STREET	5'
6. CONCRETE DRIVEWAY IN THE RIGHT-OF-WAY SHALL NOT CONTAIN REINFORCING STEEL.
7. CONCRETE DRIVEWAY IN THE RIGHT-OF-WAY FINISH SHALL BE BRUSHED WITH STIFF BRISTLED BRUSH PARALLEL TO THE CURB.
8. DRIVEWAY WIDTH DOES NOT INCLUDE WINGS.



**ASPHALT DRIVEWAY APPROACH  
WHERE CURB-GUTTER EXISTS (NO SIDEWALK)**

DRAWING NUMBER	SW-180-1
SCALE	NONE
REVISION DATE	1/25
DEPARTMENT	TRANS