

**DETAIL 1 – POLE BASE**

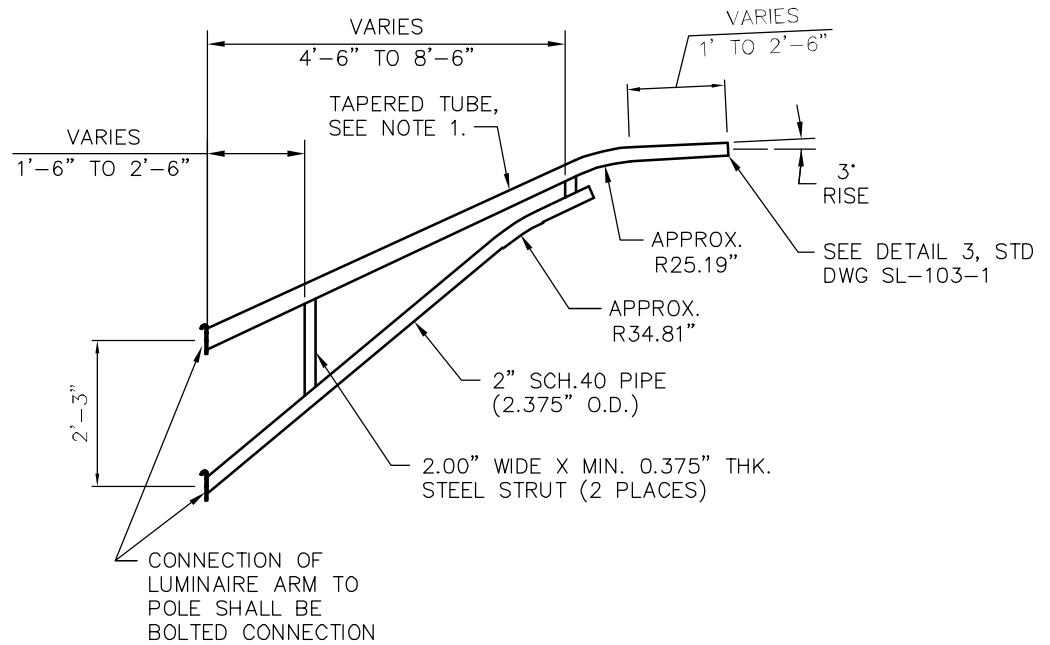

**DETAIL 2 – LUMINAIRE ARM**

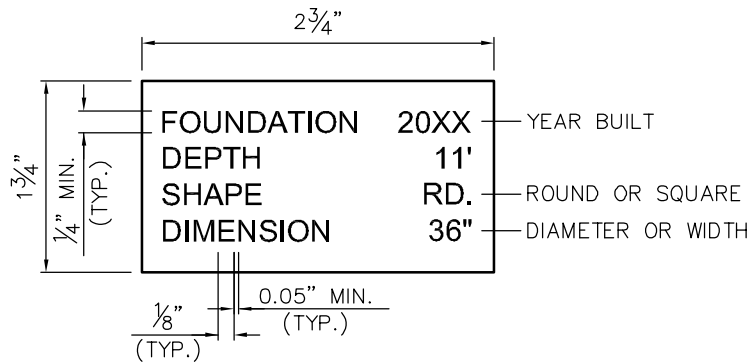

**DETAIL 3 – FOUNDATION PLATE DETAIL**

**NOTES:**

1. TAPERED TUBE HAS CROSS-SECTION OF 4.00"x2.75" (LONGER DIMENSION VERTICAL) AT CONNECTION TO POLE AND TAPERS TO A 2.75" O.D. CROSS-SECTION, THEN CONTINUES TO TAPER TO AN O.D. OF APPROX. 2.40". SEE DETAIL 3, STD DWG SL-103-1 FOR ARM END DIMENSIONS.
2. FOUNDATION PLATE MATERIAL MAY BE METAL OR PLASTIC AND SHALL BE ATTACHED TO THE POLE BASE WITH A PERMANENT WEATHERPROOF ADHESIVE.



**STEEL ROADWAY LIGHTING POLE DETAILS  
(SMALL WIRELESS FACILITY COMPATIBLE)**

DRAWING NUMBER	SL-102-1
SCALE	NONE
REVISION DATE	1/25
DEPARTMENT	TRANS