

WITHIN SCHOOL SPEED ZONE

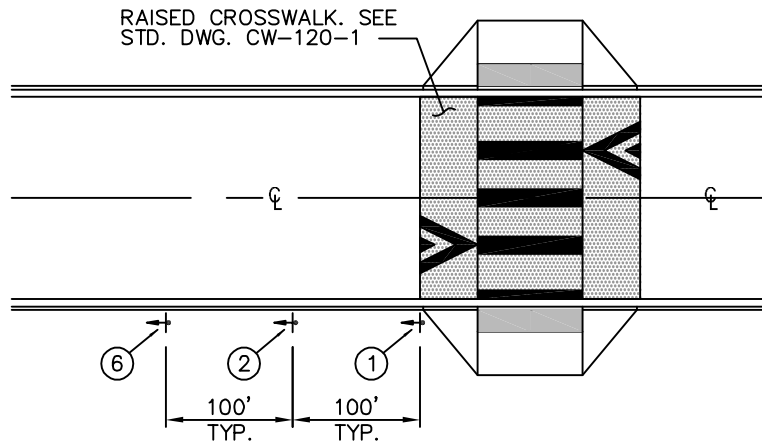

OUTSIDE SCHOOL SPEED ZONE

①

S1-1 36"x36"
W16-7P 24"x12"

②

RAISED CROSSWALK
SPECIAL 5" SERIES C LETTERS 30"x30"
15 M.P.H. W13-1 18"x18"

③

S1-1 36"x36"
S4-3P 24"x8"

④

SCHOOL SPEED LIMIT 20 WHEN FLASHING S5-1 24"x48"

(SEE NOTE 3)

⑤

SPEED LIMIT 25 R2-1 24"x30"
END SCHOOL ZONE S5-2 24"x30"

⑥

S1-1 36"x36"
W16-9P 24"x12"

NOTES:

1. SIGN COMBINATIONS ①, ②, ③, ⑥, THE "SCHOOL" LEGEND ON SIGN ④ AND ANY ADDITIONAL PLAQUES SHALL BE FLUORESCENT YELLOW-GREEN WITH BLACK LEGEND AND BORDER.
2. SIGN SPACING MAY BE ADJUSTED TO REFLECT SITE CONDITIONS AND SHALL BE APPROVED BY THE ENGINEER.
3. IN SCHOOL SPEED ZONES WITHOUT FLASHING BEACONS, USE BOTTOM MESSAGE "WHEN CHILDREN ARE PRESENT" OR AS DIRECTED BY THE ENGINEER.
4. IF ROADWAY BORDERS A SCHOOL, THIS DISTANCE MAY INCREASE AS PER RCW 46.61.440.



RAISED SCHOOL CROSSWALK SIGNING

DRAWING NUMBER	CW-160-1
SCALE	NONE
REVISION DATE	1/25
DEPARTMENT	TRANS