

DUAL SLOPED BLOCK

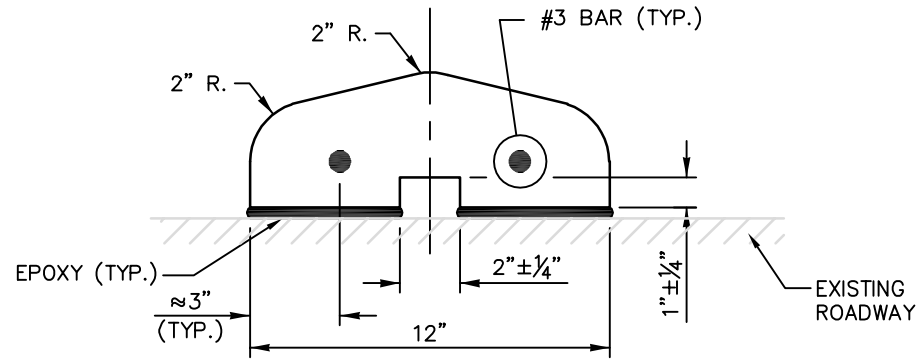

SECTION

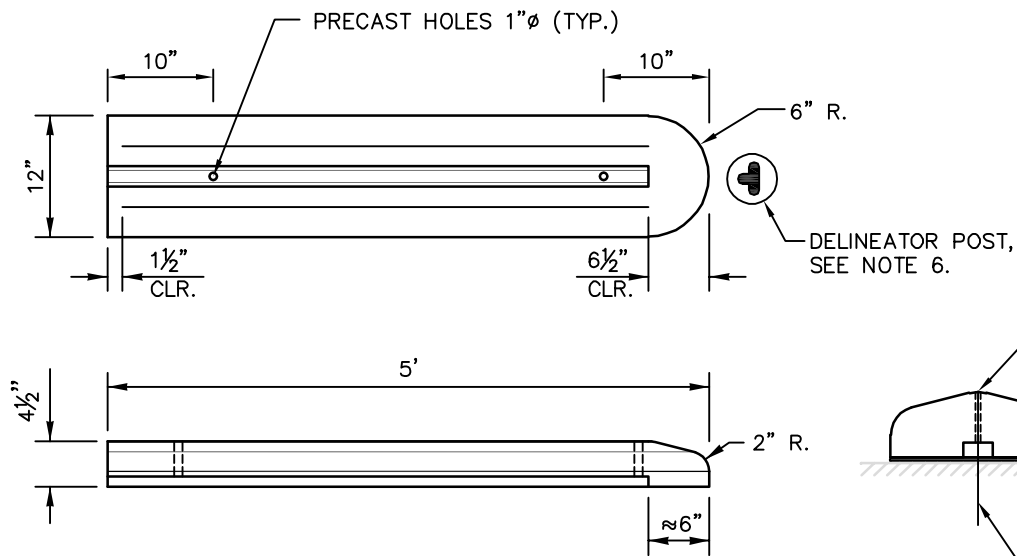

NOSING BLOCK

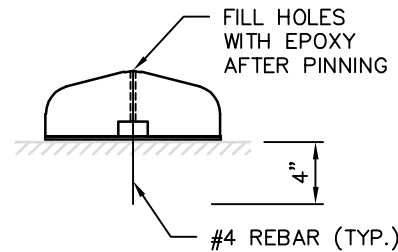

PINNING SECTION

NOTES:

1. 5' LONG STANDARD SECTIONS SHALL BE USED EXCLUSIVELY, EXCEPT TO ADJUST FOR FINAL LENGTH. NOSING BLOCK SHALL BE 5' LONG, NO EXCEPTIONS.
2. NOSING SHALL HAVE HOLES PRECAST AS SHOWN.
3. PRECAST TRAFFIC CURB SHALL BE INSTALLED WITH AN EAS-06 OR EAS-08 TWO PART EPOXY. SEE STD. DWG. CH-300-1.
4. EPOXY SHALL BE PLACED UNDER THE BEARING SURFACE OF THE PRECAST TRAFFIC CURB.
5. SUFFICIENT AMOUNT OF EPOXY SHALL BE APPLIED TO ENSURE UNIFORM COVERAGE OF APPROXIMATELY 1/4" ACROSS THE BEARING SURFACE. THE EPOXY SHALL SQUEEZE-OUT ALONG ALL EDGES.
6. DELINEATOR POST MAY BE REQUIRED AT CURB NOSE.



PRECAST CONCRETE DUAL FACED SLOPED MOUNTABLE CURB

DRAWING NUMBER	CH-150-1
SCALE	NONE
REVISION DATE	1/25
DEPARTMENT	TRANS