

DRIVEWAY APPROACH DETAIL

NOTES:

1. THIS DRIVEWAY APPROACH LAYOUT IS ONLY ALLOWED IN SPECIAL CASES SUBJECT TO APPROVAL BY THE REVIEW ENGINEER. SEE SECTION 3.5.3 OF THE DESIGN MANUAL.
2. SEE SECTION 3.5 OF THE DESIGN MANUAL FOR DRIVEWAY WIDTH, DESIGN DETAILS, AND REQUIREMENTS. DRIVEWAY WIDTH DOES NOT INCLUDE ADJACENT SIDE SLOPES (WINGS).
3. SEE SECTION 3.5 OF THE DESIGN MANUAL FOR GRADE REQUIREMENTS. SLOPE ROUNDING IS REQUIRED AT DRIVEWAY GRADE TRANSITIONS AS SHOWN IN SECTION A-A.
4. CONCRETE SHALL BE 6" TO 8" CLASS 4000 P.C.C. MIX WITH A COMPRESSIVE STRENGTH OF 3000 PSI WITHIN 3 DAYS (CURB, GUTTER, DRIVEWAY APRON, SIDE SLOPES, SIDEWALK, AND ALL OTHER ITEMS SPECIFIED BY THE ENGINEER).
5. CONCRETE PAVEMENT FINISH: BRUSHED WITH STIFF BRISTLED BRUSH PERPENDICULAR TO THE TRAVEL DIRECTION OF THE SIDEWALK.
6. $\frac{3}{8}$ " THRU EXPANSION JOINTS SHALL BE PLACED AT BACK, SIDES AND FRONT. MAXIMUM EXPANSION JOINT SPACING IS 14' CENTER TO CENTER.

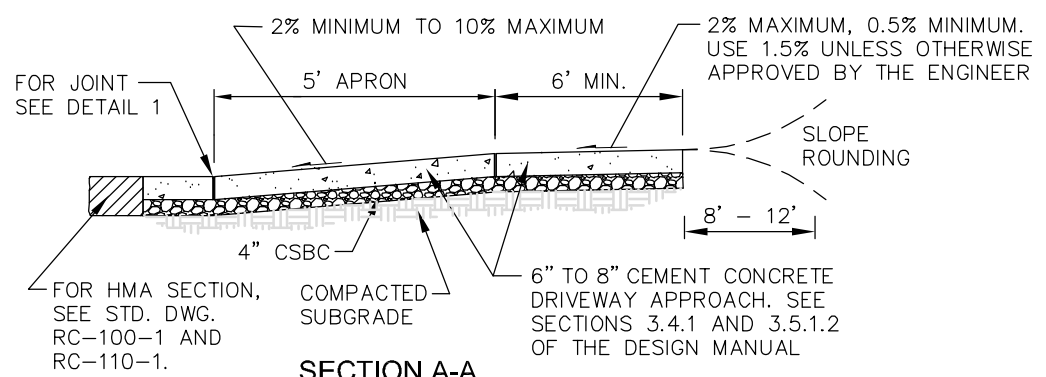

SECTION A-A

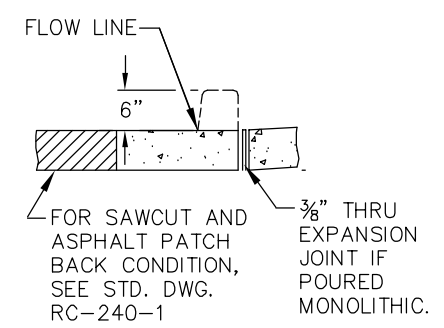

DETAIL 1



DRIVEWAY OR PRIVATE ROAD APPROACH WITH SIDEWALK (OPTION 3)

DRAWING NUMBER	SW-160-1
SCALE	NONE
REVISION DATE	2/24
DEPARTMENT	TRANS