

NOTES:

1. THE COVER SHALL HAVE 1/16" TO 1/8" CLEARANCE ON EACH EDGE WITHIN THE FRAME GALVANIZING
2. CONDUIT ELBOWS OR SWEEPS INTO JUNCTION BOX SHALL BE DETERMINED IN THE FIELD BY THE INSPECTOR.
3. DISTANCE BETWEEN THE TOP OF THE CONDUIT AND THE BOTTOM OF THE LID SHALL BE 10" MIN. TO 12" MAX.
4. JUNCTION BOX SHALL BE PLACED ON MINIMUM 6" THICK PEA GRAVEL PAD.

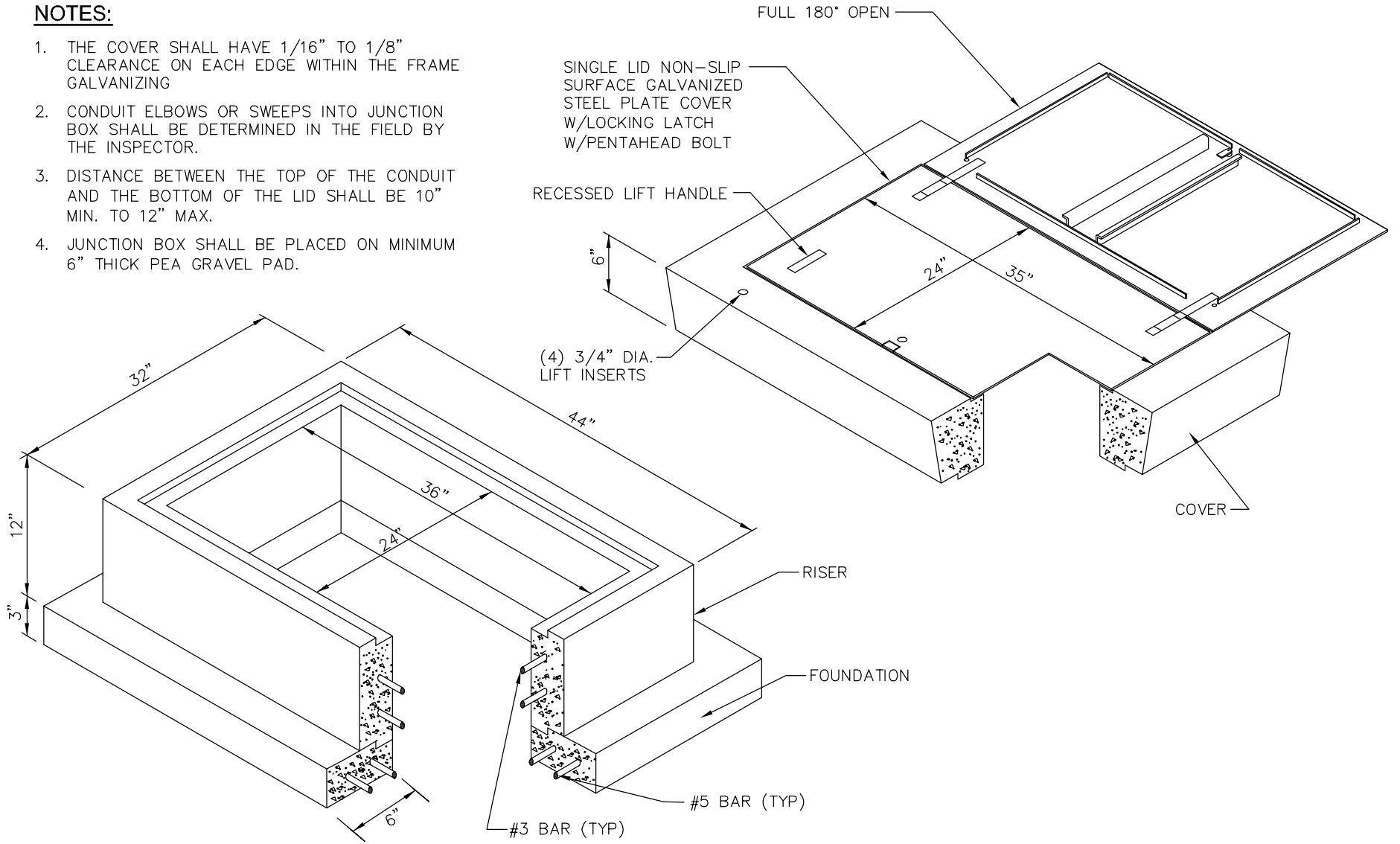

TYPE 8 MODIFIED JUNCTION BOX

DRAWING NUMBER	SL-170-1
SCALE	NONE
REVISION DATE	2/24
DEPARTMENT	TRANS