

ANCHOR BOLT TEMPLATE DETAIL

TWO NON-INSULATED #4 AWG STRANDED COPPER GROUNDING CONDUCTORS. PROVIDE 3' MIN. SLACK (ROUTE CONDUCTORS TO GROUNDING STUD)

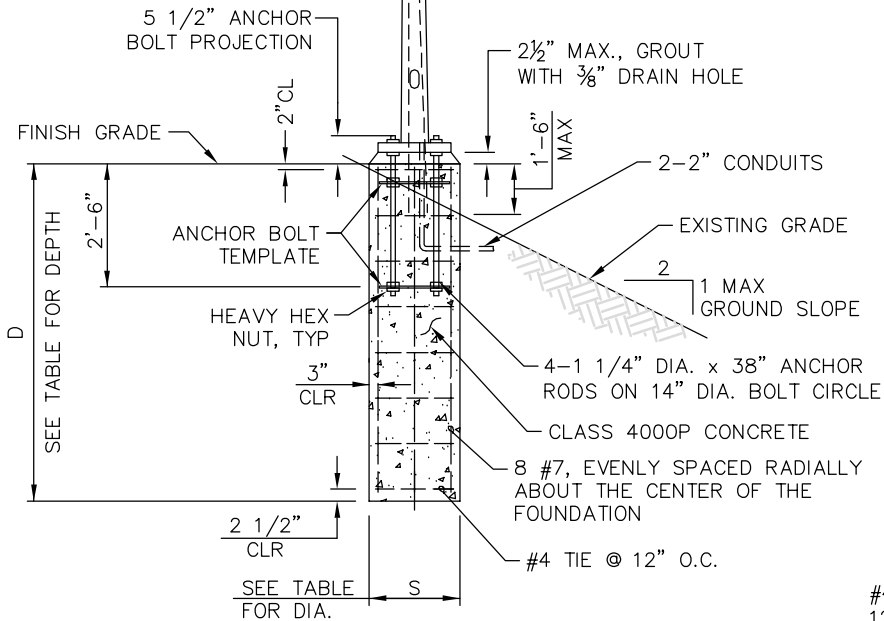

FOUNDATION – SLOPED GROUND CONDITION

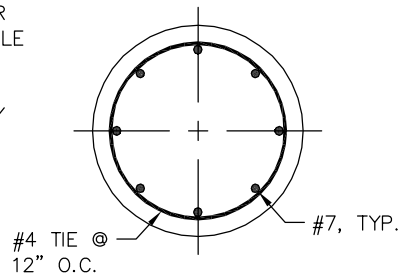

FOUNDATION SECTION

NOTES:

1. THE FOUNDATION HAS BEEN DESIGNED ACCORDING TO THE AASHTO LRFD SPECIFICATIONS FOR STRUCTURAL SUPPORTS FOR HIGHWAY SIGNS, LUMINAIRES AND TRAFFIC SIGNALS, FIRST EDITION, 2015. ULTIMATE WIND SPEED IS 120 MPH.
2. THE FOUNDATION HAS BEEN DESIGNED FOR THE FOLLOWING POLE BASE FORCES:

BENDING MOMENT:	41,816 FT-LB
TORSION:	2,330 FT-LB
SHEAR FORCE:	1,814 LB
AXIAL FORCE:	1,798 LB
3. FOUNDATIONS FOR POLES WITH FORCES GREATER THAN ONE OR MORE OF THE FORCES LISTED ABOVE SHALL REQUIRE SPECIAL DESIGN.
4. ANCHOR BOLTS, NUTS AND WASHERS SHALL BE HOT DIPPED GALVANIZED FULL LENGTH PER ASTM A153 OR F2329. ANCHOR BOLTS SHALL CONFORM TO ASTM F1554, GRADE 55, WITH 14" OF THREADS AT TOP AND 6" OF THREADS AT BOTTOM. HEAVY HEX NUTS SHALL CONFORM TO ASTM A563, GRADE A. WASHERS SHALL CONFORM TO ASTM F436.
5. CLAMP CONDUCTORS TO STEEL REINFORCING WITH LISTED CONNECTOR SUITABLE FOR USE EMBEDDED IN CONCRETE.
6. REINFORCING STEEL SHALL CONFORM TO ASTM A706, GRADE 60.

FOUNDATION DEPTH "D"			
ALLOWABLE LATERAL BEARING PRESSURE	SHAFT DIA. S	GROUND SLOPE	
		SLOPE 4H:1V OR FLATTER	SLOPE BTWN 4H:1V & 2H:1V
1000 TO 1500 PSF	30"	11'	SPECIAL DESIGN REQ'D
	36"	10'	SPECIAL DESIGN REQ'D
GREATER THAN 1500 PSF	30"	8'	10'
	36"	7'-6"	9'



**ROADWAY LIGHTING POLE FOUNDATION WITHIN UNPAVED AREA
(SMALL WIRELESS FACILITY COMPATIBLE)**

DRAWING NUMBER	SL-106-1
SCALE	NONE
REVISION DATE	2/24
DEPARTMENT	TRANS