

PLAN VIEW
NTS

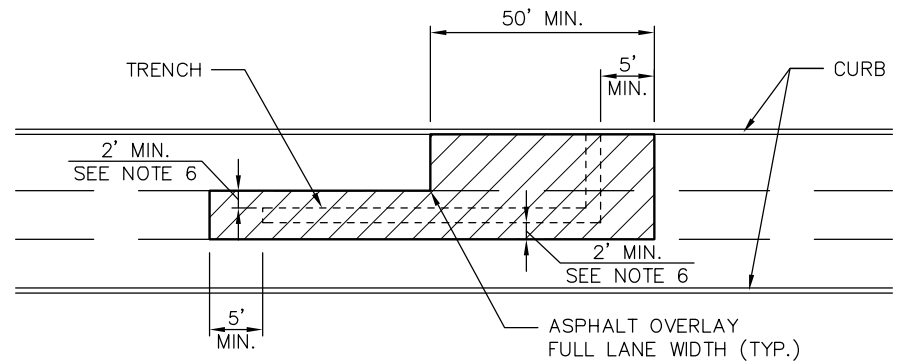

PLAN VIEW
NTS

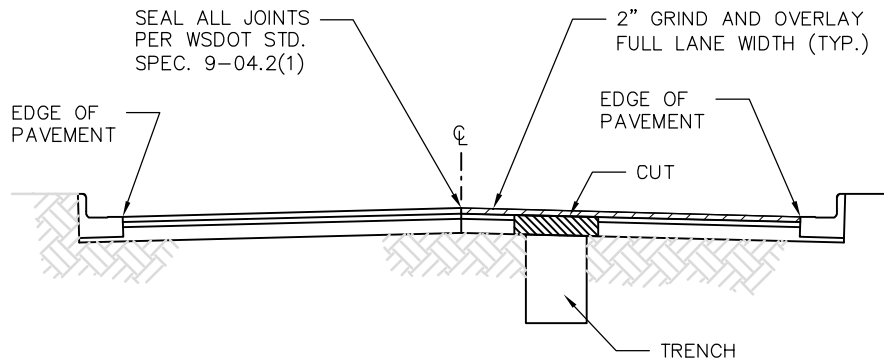

SECTION A-A
NTS

NOTES:

1. THIS STANDARD APPLIES TO ALL CUTS IN ROADWAY DESIGNATED ON THE CURRENT TRENCH RESTORATION MAP.
2. GRIND/OVERLAY WITHIN SIGNAL LOOP DETECTION ZONE MAY BE EXTENDED TO INCLUDE ADDITIONAL LANES AND/OR DETECTORS
3. OVERLAY AREA MAY BE EXTENDED AT THE DISCRETION OF THE TRANSPORTATION ENGINEER TO ENCOMPASS ADJACENT STREET CUTS OR PREVIOUS RESTORATIONS.
4. ADJUST ALL UTILITY CASTINGS TO FINISHED GRADE AFTER OVERLAY AND RESTORE CHANNELIZATION AND LOOP DETECTION.
5. WHERE NO MARKED LANE LINE EXISTS, GRIND SHALL EXTEND TO CENTERLINE OF TRAVELED WAY OR PHYSICAL CROWN OF ROADWAY.
6. IF EDGE OF TRENCH IS LESS THAN 2-FT FROM LANE LINE, OVERLAY SHALL INCLUDE FULL WIDTH OF ADJACENT LANE.



ASPHALT OVERLAY FOR ROADWAY TRENCH RESTORATION

DRAWING NUMBER	RC-200-1
SCALE	NONE
REVISION DATE	2/24
DEPARTMENT	TRANS