

SLEEVE WRAPPED

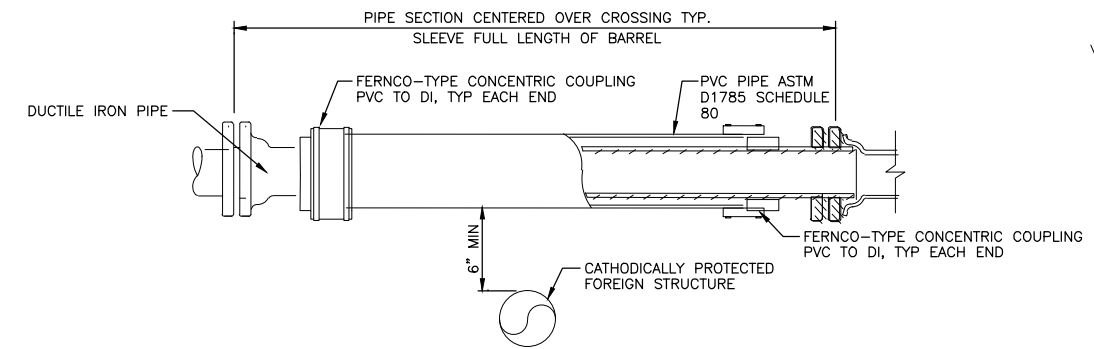

SLEEVE SLIP-ON FOR DI PIPE

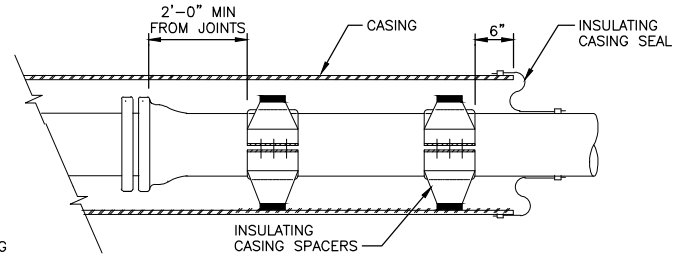

- NOTES:**
1. PROVIDE A SPACER WITHIN 6" OF EACH CASING END. PROVIDE INTERMEDIATE SPACERS AS REQUIRED, NOT TO EXCEED THE MAXIMUM DISTANCE SPECIFIED BY THE MANUFACTURER.
 2. INSTALL CASING SEAL PER MANUFACTURER REQUIREMENTS TO PREVENT TENSIONING SEAL DURING BACKFILL.

CASING SPACERS & END SEALS

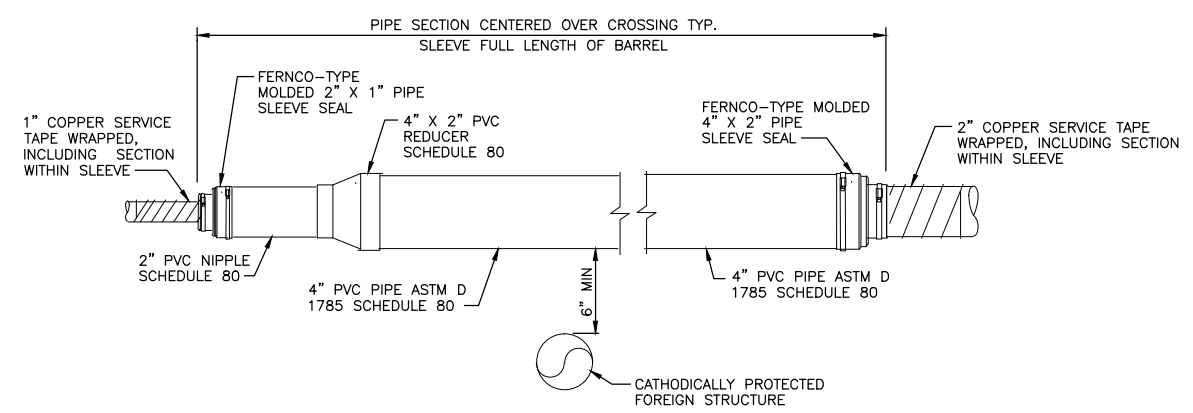

**SLEEVE SLIP-ON FOR COPPER SERVICE
1" OR 2" COPPER SHOWN**

SLEEVED AND CASED PIPE DETAILS 1
SCALE: NTS

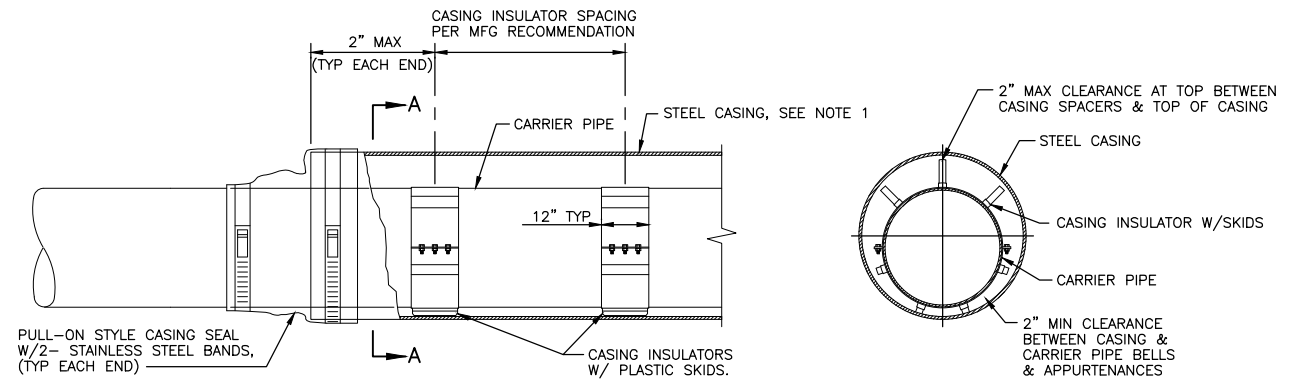

- NOTES:**
1. SEE SPECIFICATIONS FOR CASING AND CASING COATING REQUIREMENTS.
 2. SEE SPECIFICATIONS AND DRAWINGS FOR CASING CATHODIC PROTECTION REQUIREMENTS.
 3. SEE DETAIL 2, SHEET 1, FOR CASING TEST STATION REQUIREMENTS.

STEEL CASING DETAIL 2
SCALE: NTS

- GENERAL NOTES:**
1. PROVIDE A SLEEVE WHEN CROSSING OVER OR UNDER POTENTIAL STRAY CURRENT SOURCES.
 2. WHEN SLEEVING A PIPE JOINT PROVIDE 2 CASING SPACERS, 1 EACH SIDE OF JOINT.
 3. COPPER SHALL BE WRAPPED WITH 20 MIL PVC TAPE, 50% OVERLAP, 40 MIL TOTAL, INSIDE & OUTSIDE PVC SLEEVE.
 4. OVERLAP GEOMEMBRANE SHEETING A MINIMUM OF 1/4 THE OF PIPE CIRCUMFERENCE. ENSURE OVERLAP RUNS ALONG CROWN OF PIPE.
 5. SLEEVES AND CASINGS SHALL BE DRY & MOISTURE FREE BEFORE SEALING.

January 2024

DESIGNED	ACE	APPROVED			<p>ACE Consultants, Inc. Beaverton, Oregon (503) 626-2320</p>	<p>CITY OF BELLEVUE WASHINGTON</p>	<p>CATHODIC PROTECTION STANDARD DETAIL - EL - 4</p>		
DRAWN	ACE	SCALE	AS SHOWN					DATE	AUG 2012
CHECKED	ACE	FILE	X						
DATE	NO.	REVISIONS	BY						