

**MARKING DETAIL**

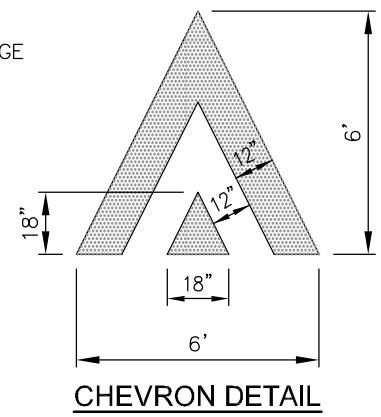

**CHEVRON DETAIL**

**NOTES:**

1. RAISED CROSSWALK CHEVRON MARKING SHALL BE THERMOPLASTIC, HEAT FUSED PREFORMED, 90 MIL., OR EQUAL APPROVED BY THE ENGINEER.
2. CHEVRON TO BE CENTERED IN THE DRIVING LANE. LOCATION SHALL BE VERIFIED BY THE ENGINEER PRIOR TO INSTALLATION.
3. RAISED CROSSWALK SHALL BE CONSTRUCTED ON TOP OF NEW OR EXISTING WEARING COURSE USING CITY PROVIDED TEMPLATE, 48 HOURS NOTICE REQUIRED.

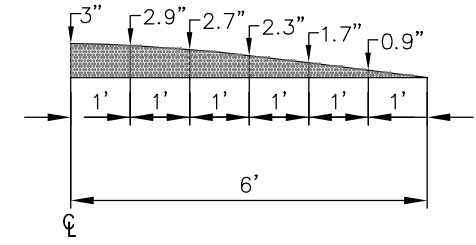

**APPROACH ARC DETAIL**

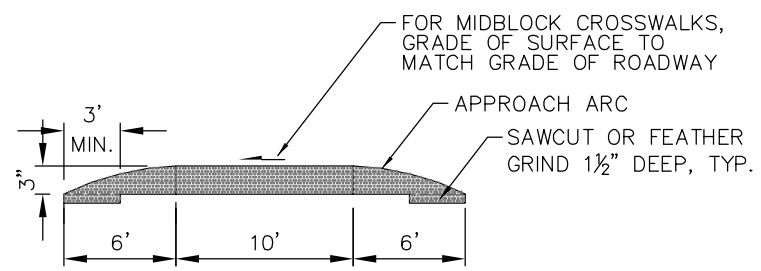

**CROSS SECTION A-A**

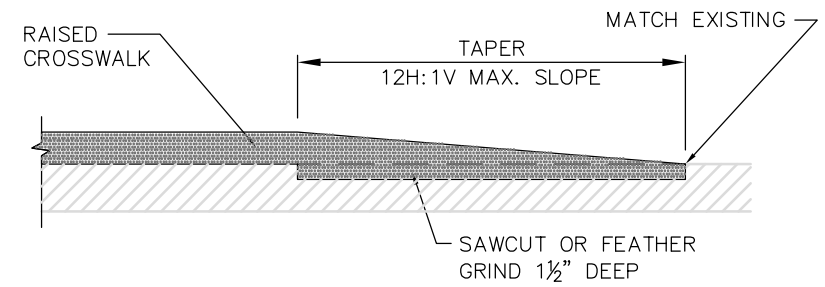

**LONGITUDINAL SECTION - RAISED CROSSWALK AT ASPHALT SHOULDER**



**RAISED CROSSWALK**

|                |          |
|----------------|----------|
| DRAWING NUMBER | CW-120-1 |
| SCALE          | NONE     |
| REVISION DATE  | 2/24     |
| DEPARTMENT     | TRANS    |