

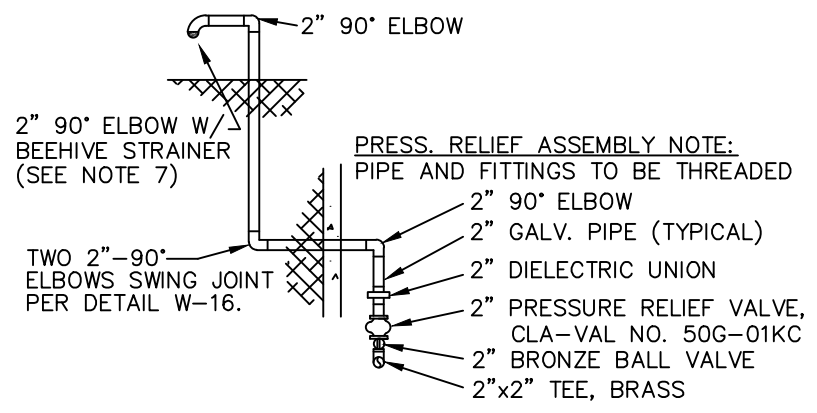

- NOTES:**
1. SIZING OF VALVES WILL BE MODIFIED FOR OTHER SIZES OF PIPE.
 2. GALVANIZED LADDER TO BE SECURED TO VAULT PER STD. DTL. NO. W-19.
 3. ALL P.R.V.s SHALL HAVE OPENING/CLOSING SPEED CONTROLS, EPOXY COATED BODY AND VALVE POSITION INDICATOR, CLA-VAL X101.
 4. PILOT CONTROLS SHALL BE ON SIDE OF P.R.V. FACING INTERIOR OF VAULT TO PROVIDE EASY ACCESS.
 5. ALL CLA-VAL PRVs AND PRESSURE RELIEF VALVES SHALL BE EQUIPPED W/STAINLESS STEEL TRIM (SEAT, STEM & COVER BEARING).
 6. SEAL ALL PIPE PENETRATIONS THROUGH VAULT W/ LINK SEAL MODULAR SEALS.
 7. PRESSURE RELIEF DISCHARGE DOWNSPOUT SHALL DIRECT WATER TOWARDS CENTER OF INLET GRATE.
 8. HATCH AND LADDER PER DETAIL W-19.
 9. PROVIDE LADDER-UP EXTENSION, BILCO MODEL LU-2, OR APPROVED EQUAL.
 10. MINIMUM 2' OF LEVEL, UNOBSTRUCTED AREA AROUND HATCHES.
 11. PROVIDE CAST OR FIELD CORE DRILLED HOLES THROUGH VAULT WALLS FOR PIPE PENETRATIONS.



2" PRESSURE RELIEF ASSEMBLY

	<h1 style="margin: 0;">City of Bellevue</h1>	<p>WATER UTILITY</p>
<p>TITLE</p> <h2 style="margin: 0;">STANDARD PRESSURE REDUCING STATION</h2>		
<p>JANUARY 2023</p>	<p>NO SCALE</p>	<p>NO. W-17</p>