

PLAN - CURBSIDE SIDEWALK

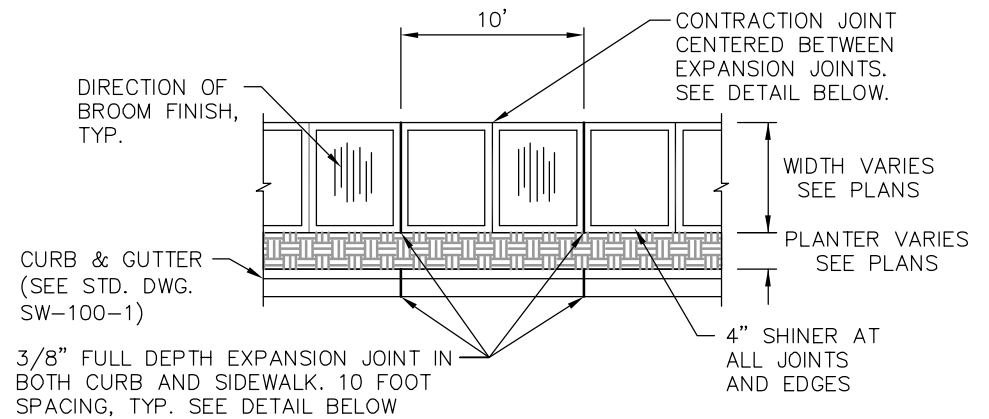

PLAN - SIDEWALK WITH PLANTER STRIP

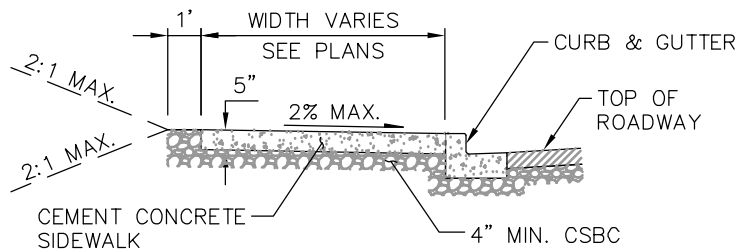

SECTION - CURBSIDE SIDEWALK

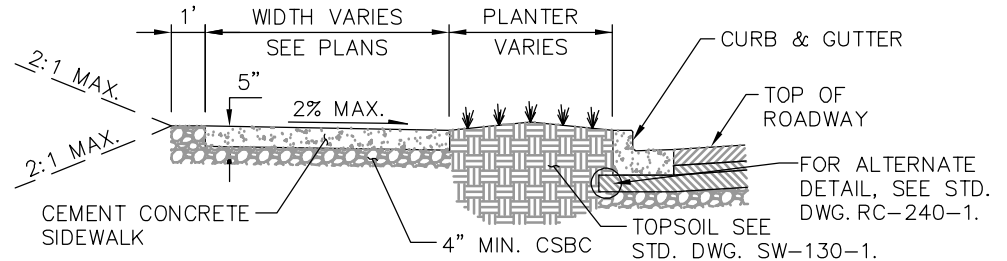

SECTION - SIDEWALK WITH PLANTER STRIP

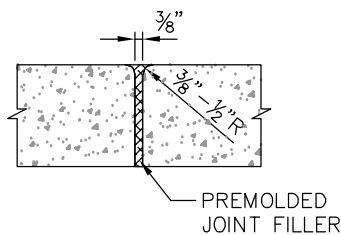

FULL DEPTH EXPANSION JOINT DETAIL

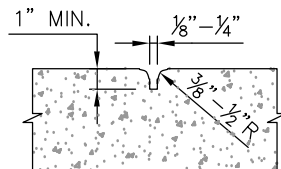

CONTRACTION JOINT DETAIL

NOTES:

1. CONCRETE SHALL BE AIR ENTRAINED CLASS 3000 PER SECTION 6-02 OF WSDOT STANDARD SPECIFICATIONS.
2. FINISH: LIGHT FINISH WITH A STIFF BROOM PERPENDICULAR TO CURB. FOR GRADES OVER 4%, FINISH WITH A STIPPLE BRUSH.
3. REMOVAL/REPLACEMENT OF CEMENT CONCRETE CURB AND SIDEWALK SHALL BE FROM EXPANSION JOINT TO EXPANSION JOINT UNLESS OTHERWISE DIRECTED BY THE ENGINEER.
4. LIDS FOR JUNCTION BOXES AND UTILITY VAULTS SHALL BE NON-SLIP AS SPECIFIED BY THE ENGINEER.



SIDEWALK

DRAWING NUMBER	SW-110-1
SCALE	NONE
REVISION DATE	12/22
DEPARTMENT	TRANS