

- 1 FRAME—CAST IRON
- 2 COVER—CAST IRON
- 3 ARCH—CAST IRON
- 4 RAILS—304 STN. STL.  
(CAST IRON, THRU 14")
- 5 YOKE—CAST IRON
- 6 THRUST NUT—BRONZE
- 7 THREADED STEM—BRONZE
- 8 COLLAR—CAST IRON
- 9 STEM EXT BRKT—
- 10 STEEL EXT STEM  
MATL. AS REQ'D.
- 11 2" SQUARE OPERATING NUT
- 12 BRONZE SEAT

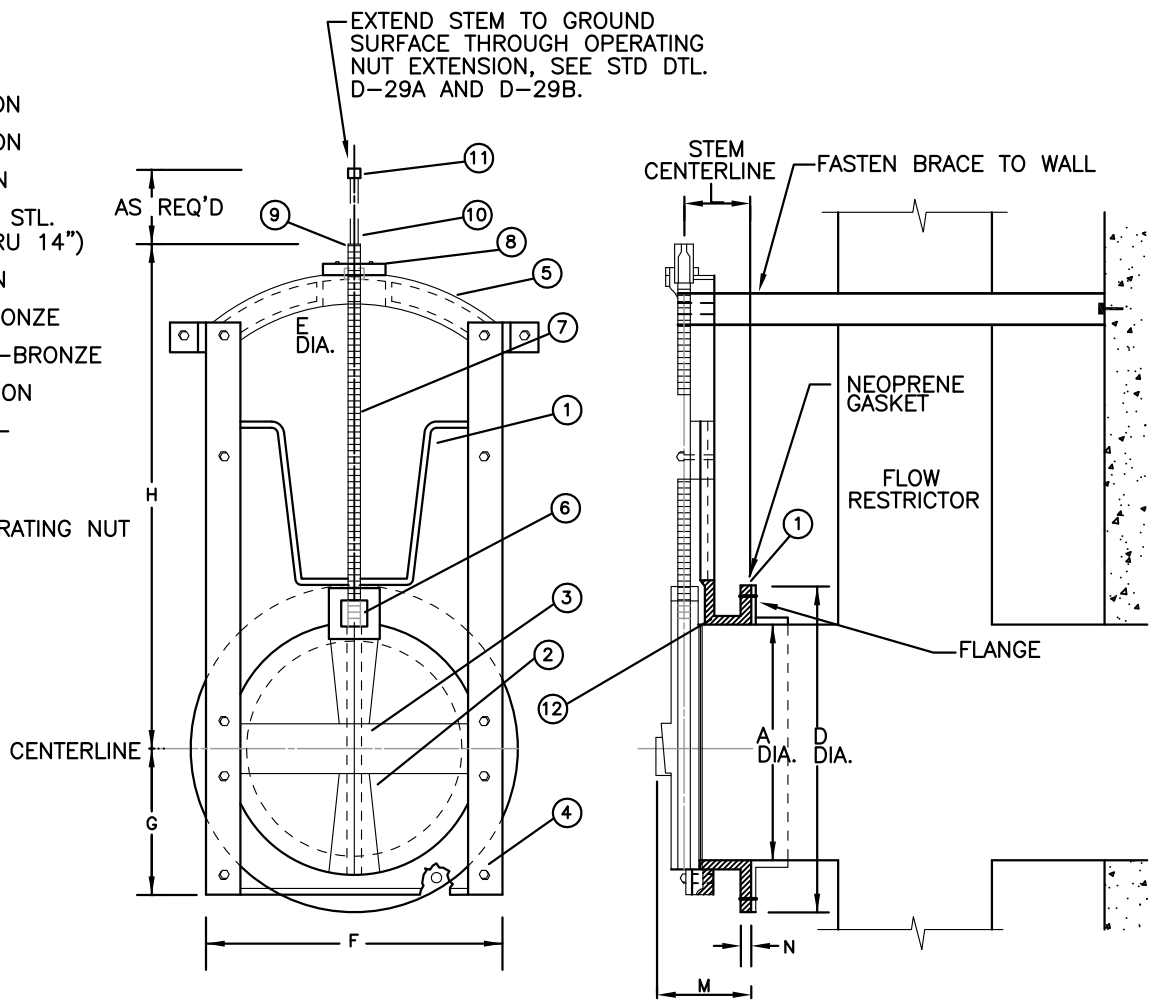

	A	BC	D	E	F	G	H	K	L	M	N	P	R	S
DIMENSIONS (IN INCHES)	8	11 3/4	13 1/2	7/8	11 1/8	5 1/2	17 5/8	10	4 1/2	7	3/4	7/8	3/4	8
	12	17	19	7/8	15 5/8	8	24 1/4	12	4 1/2	7 1/2	1	1	7/8	12

**NOTES:**

- 1. FOR OUTLET PIPE DIAMETERS OF 12 INCHES OR LESS, USE 8 INCH SHEAR GATE, GREATER THAN 12 INCHES, USE 12 INCH SHEAR GATE.
- 2. AWWA C509 RESILIENT SEATED GATE VALVE MAY BE SUBSTITUTED FOR GATE PER ENGINEER'S APPROVAL.



City of  
Bellevue

STORM AND SURFACE  
WATER UTILITY

TITLE

SCREW-TYPE  
SHEAR GATE