

**MATERIALS LIST-** (ALL SIZES ARE SAME AS METER UNLESS OTHERWISE LISTED)

- ① 2-MECH. CPLG. TO FIT, EQUAL TO MJ SLEEVE OR ROMAC 501 (4"x3" REDUCER, M.J. FOR 3" METER INSTALLATION ON UPSTREAM SIDE OF VAULT).
- ② 2-GATE VALVE, FLANGE.
- ③ 1-SENSUS OMNI C2 METER WITH INTERNAL STRAINER WITH ELECTRONIC RESOLUTION (100'S OF CUBIC FEET) REGISTER.
- ④ 1-D.I. ADPT. FL.xPE. LENGTH TO FIT.
- ⑤ 1-CPLG. ADPT., FL. ROMAC - RESTRAINED FCA 501.
- ⑥ PRECAST CONC. VAULT BY OLDCASTLE PRECAST (577-LA. OR APPROVED EQUAL) WITH TWO DIAMOND PLATE DOORS RATED FOR H-30 LOADING W/ 8" OFFSET, SEE NOTE 7.
- ⑦ WELDED FL. RESTRAINT OR MEGALUG MID-SPAN RESTRAINT AND THRUST BLOCK ADJACENT TO VAULT STANDARD DETAIL W-56.
- ⑧ CONNECT THE FOLLOWING TO METER TEST PORT. 1-2" BRASS NIPPLE, M.I.P.T. x M.I.P.T. AND 2" F.I.P.T. x 2 1/2" M.N.S.T. PLUS CAP (2 1/2" M.N.S.T.), 6" LONG 1-2" BALL VALVE, F.I.P.T. X M.I.P.T. FORD B81-777, OR APPROVED EQUAL.
- ⑨ 1-GALVANIZED STEEL LADDER TO BE ATTACHED TO VAULT. SEE NOTE 12.
- ⑩ TR/PL SENSOR (TO MOUNT IN VAULT ACCESS DOOR).

**PLAN**

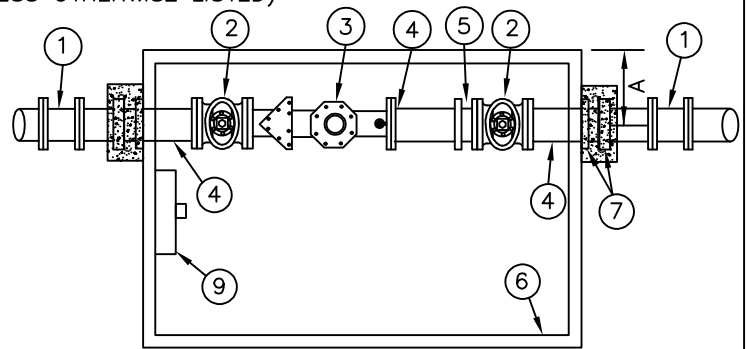

10. PROVIDE 24" CLEARANCE BETWEEN VAULT FLOOR & BOTTOM OF METER, WHERE ELEVATION OF VAULT FLOOR IS TOO LOW TO DRAIN TO DAYLIGHT OR STORM SYSTEM. THIS CLEARANCE CAN BE REDUCED TO A MINIMUM OF 12", IF SUBSTITUTION OF A SHORTER VAULT ALLOWS FLOOR TO DRAIN TO DAYLIGHT OR STORM SYSTEM (APPROVED BY THE UTILITY ON A CASE BY CASE BASIS ONLY.) SUBSTITUTE VAULT AS FOLLOWS: 575-LA WITH LW PRODUCTS HHD-48"x48" COVER, OR APPROVED EQUAL, (WITH SPECIAL OFFSET) ALLOWED ONLY ON 3" AND 4" METERS.
11. PROVIDE 2 1/4" DIAM. OPENING IN ALUMINUM HATCH DOOR FOR TR/PL SENSOR.
12. LADDER TO BE SECURED TO VAULT AT A MINIMUM OF 2 LOCATIONS, ONE AT FLOOR AND ONE AT TOP. SUPPORTS SHALL NOT BE MORE THAN 10' APART. RUNGS SHALL BE SPACED AT 12" ON CENTER. LADDER SHALL INCLUDE BILCO MODEL LU-2 LADDER-UP, OR APPROVED EQUAL. SEE DETAIL 19.
13. A FULL FLOW BYPASS MAY BE REQUIRED, DEPENDING ON APPLICATION. TO BE DETERMINED BY THE CITY.

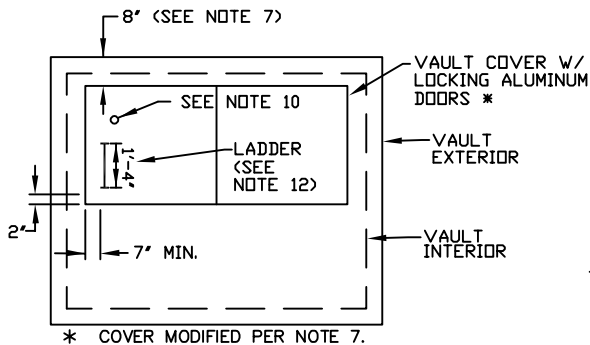

**NOTES:**

1. ALL MATERIALS INCLUDING METER SHALL BE FURNISHED BY CONTRACTOR.
2. ALL PIPE & FITTINGS 3" AND LARGER SHALL BE CEMENT LINED DUCTILE IRON, CLASS 52 MINIMUM.
3. PIPING FROM MAIN TO VAULT SHALL BE 4" ON 3" METER INSTALLATION. TEE WITH VALVE ON EXISTING MAIN REQUIRED.
4. VAULTS SHALL NOT BE INSTALLED IN AREAS WITH VEHICULAR TRAFFIC.
5. TEST PORT NOZZLE SHALL BE DIRECTED UPWARD UNLESS OTHERWISE DIRECTED, (SEE ITEM 8).
6. IN CENTRAL BUSINESS DISTRICT, CONNECT TO WATER MAIN WITH 8" PIPE. SUBSTITUTE 8" X SERVICE SIZE REDUCER, MJ, FOR ITEM 1 ON UPSTREAM SIDE OF VAULT.
7. VAULT COVER SHALL INCLUDE 2 LOCKING ALUMINUM HATCH DOORS WITH SLIP RESISTANT TREATMENT PER SECTION W4-17 OF THE ENGINEERING STANDARDS. DOORS SHALL BE CAST IN COVER WITH 8" SPECIAL OFFSET FROM VAULT WALL, AS SHOWN. COVER TO READ "WATER".
8. MINIMUM 2' OF LEVEL, UNOBSTRUCTED AREA AROUND HATCHES.
9. VAULT SHALL HAVE COAL TAR COATING OF 5 TO 9 MILS APPLIED TO THE EXTERIOR.

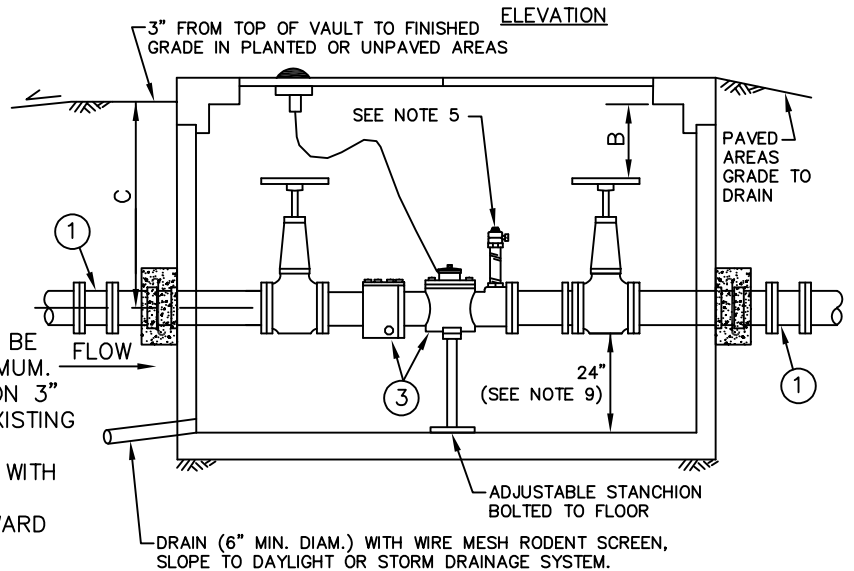

METER SIZE	SERVICE LINE	CORP. STOP FOR METER TESTING SIZE	MINIMUM CLEARANCES			
			A	B	C	D
3"	4"D.I.	2"	10"	6"	2'-8"	9"
4"	4"D.I.	2"	12"	6"	2'-8"	9"
6"	6"D.I.	2"	13"	6"	3'-2"	6"



City of Bellevue

WATER UTILITY

TITLE

3" TO 6" IRRIGATION METER INSTALLATION