

PRIVATE PLUMBING SHALL CONNECT HERE  
 SETTER SHALL BE POSITIONED TO:  
 CENTER RIGID SPREADER (I)  
 UNDER INSPECTION LID AND  
 PROVIDE ADEQUATE CLEARANCE  
 BETWEEN BYPASS AND BOX WALL  
 FOR OPERATING AND LOCKING  
 BYPASS VALVE.

- (A) DUCTILE IRON TEE WITH 4" BRANCH, FL WITH (3) GATE VALVES UNLESS OTHERWISE APPROVED BY UTILITY.
- (B) 4" GATE VALVE, FL.
- (C) 4" REDUCING COMPANION FLANGE WITH 2" TAP.
- (D) COUPLING, 2" MALE IRON PIPE THREAD BY 2" PACK JOINT (COMPRESSION FITTING) FOR COPPER, FORD C84-77-NL, MUELLER NO. P-15428N, OR APPROVED EQUAL.
- (E) 2" COPPER TUBING, TYPE K.
- (F) 2" STREET ELL, BRASS, FEMALE IRON PIPE THREAD BY FEMALE IRON PIPE THREAD.
- (G) 2" NIPPLE, BRASS, M.I.P.T. x M.I.P.T., LENGTH AS REQUIRED TO MEET PROPER GRADE.
- (H) 2" BRASS AND COPPER METER SETTER WITH LOW BYPASS:  
 -FLANGED BALL METER VALVE ON INLET AND OUTLET  
 -BALL VALVE ON BYPASS  
 -PADLOCK WINGS ON ALL VALVES  
 -VERTICAL INLET AND OUTLET, F.I.P.T.  
 -BUSHING INCLUDED ON OUTLET  
 FORD VBB87-12B-11-77-NL OR A.Y. MCDONALD 730B712WWFF665 VERTICAL METER SETTER WITH VALVE ROTATED 90 DEG., OR APPROVED EQUAL.
- (I) RIGID METER SPREADER, SUPPLIED BY CITY OF BELLEVUE, TO BE INSTALLED IN METER SETTER BY CONTRACTOR.
- (J) METER BOX IN LANDSCAPING: CARSON INDUSTRIES 1730-18 BCF BOX. COVER SHALL BE COMPOSITE MATERIAL, MARKED "WATER METER", WITH 2" AMR RECESS (CARSON, FIBRELYTE FL36, OR NICOR B36).  
  
 METER BOX IN SIDEWALKS AND AREAS WITH VEHICULAR TRAFFIC: OLYMPIC FOUNDRY SM30 BOX AND COVER.
- (K) TWO PIECE CAST IRON VALVE BOX TO FIT, RICH SEATTLE TYPE #045 - WITH RECESSED HANDLE LID, OR APPROVED EQUAL. SEE DETAIL W-11.

**NOTES:**

1. SERVICE LINE SHALL BE PERPENDICULAR TO THE WATERMAIN, UNLESS OTHERWISE APPROVED BY THE ENGINEER.
2. BYPASS WILL BE LOCKED OFF BY CONSTRUCTION INSPECTOR WHEN METER SPREADER IS INSTALLED.
3. METER WILL BE SUPPLIED AND INSTALLED BY THE CITY OF BELLEVUE.

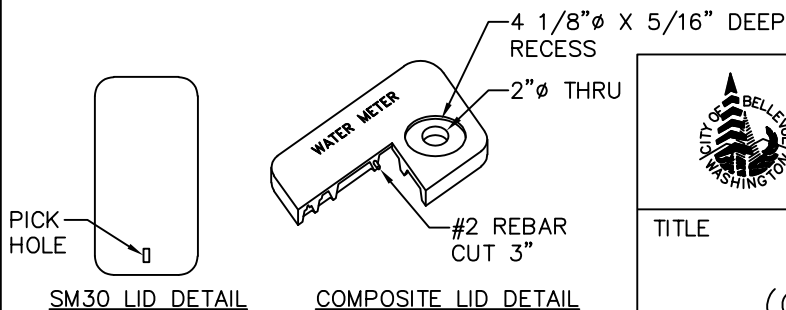

JANUARY 2025

NO SCALE



City of  
Bellevue

WATER UTILITY

TITLE

2" DOMESTIC WATER SERVICE  
(COMMERCIAL AND MULTI-FAMILY)

NO. W-30