

PARKING LOT/ AREA
GRATE AND FRAME
PER STANDARDS

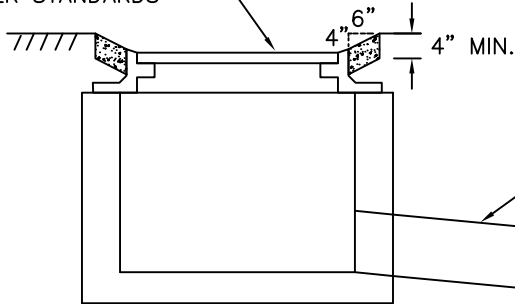

CONCRETE INLET
PER STANDARDS

PRESSURE RELIEF DRAIN

VAULTS WITH HATCH
ACCESS SHALL NOT BE
INSTALLED IN AREAS
WITH VEHICULAR
TRAFFIC. INSTALL IN
SHOULDERS, SIDEWALKS
OR LANDSCAPED AREAS
ONLY. TO READ **WATER**.

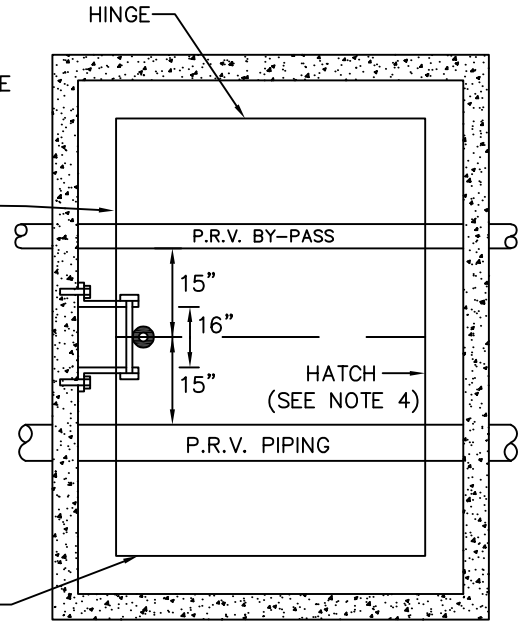

PLAN VIEW

FIRST STEP MAXIMUM
12" BELOW TOP OF
COVER.

CONCRETE MECHANICAL
ANCHOR BOLT, GALVANIZED
OR STAINLESS STEEL
(TYPICAL)

SIDE RAIL AND
BRACKET, 1 1/2" x
1/4" GALV. STEEL
(TYPICAL)

RUNG, NO. 8 DEFORMED
REINFORCING BAR
CONFORMING TO
ASTM A 615

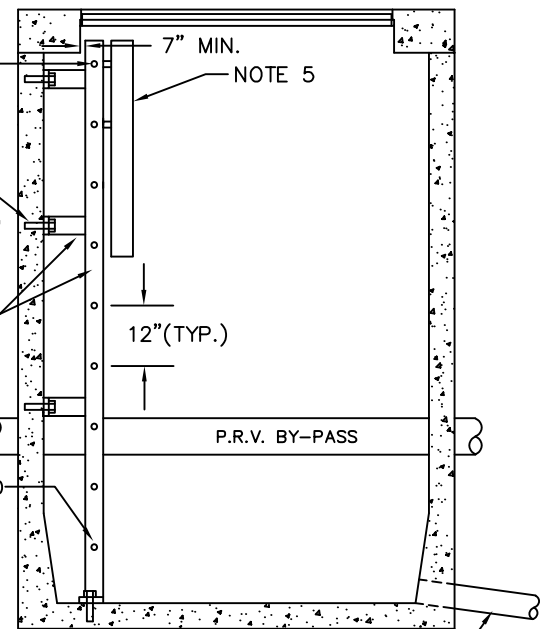

6" DIA DRAIN TO DAYLIGHT
OR STORM SYSTEM (WIRE
MESH RODENT SCREEN
OVER DRAIN).

ELEVATION VIEW

NOTES:

1. LADDER TO BE SECURED TO VAULT AT A MINIMUM OF 2 LOCATIONS, ONE AT FLOOR AND ONE AT TOP. SUPPORTS SHALL NOT BE MORE THAN 10' APART.
2. ALL LADDER PARTS TO BE GALVANIZED CONFORMING TO ASTM A 123
3. LOCATE PRESSURE RELIEF DRAIN OUTSIDE PEDESTRIAN AND TRAFFIC AREAS.
4. ACCESS HATCH SHALL BE LOCKING ALUMINUM LW PRODUCTS HHD 48"x60" DOUBLE DOOR MODEL RATED FOR H-30 LOADING WITH SLIP RESISTANT TREATMENT PER SECTION W4-17 OF THE ENGINEERING STANDARDS OR APPROVED EQUAL. HATCHES SHALL INCLUDE RECESSED PADLOCK HASP SIZED TO ACCEPT CITY OF BELLEVUE WATER DIVISION PADLOCKS (CONTACT LW PRODUCTS).
5. LADDER-UP ATTACHMENT REQUIRED ON ALL VAULT LADDERS. BILCO MODEL LU-2, OR APPROVED EQUAL.
6. MANHOLE LID IS OPTIONAL ONLY WHEN STATION COVER IS LOCATED IN TRAFFIC.
7. DRAIN HATCH GUTTER DRAIN TO EXISTING CB OR DAYLIGHT.



City of
Bellevue

WATER UTILITY

TITLE

PRESSURE REDUCING STATION
ACCESS LADDER
AND PRESSURE RELIEF DRAIN

NO. W-19

JANUARY 2025

NO SCALE