

OFFSET FRAME SO THAT TEE AND GATE ARE VISIBLE AT EDGE OF OPENING AND DIRECTLY OVER THE STEPS

24" ACCESS MANHOLE W/BOLT LOCKING RING AND COVER PER STANDARDS, SEE NOTE 2

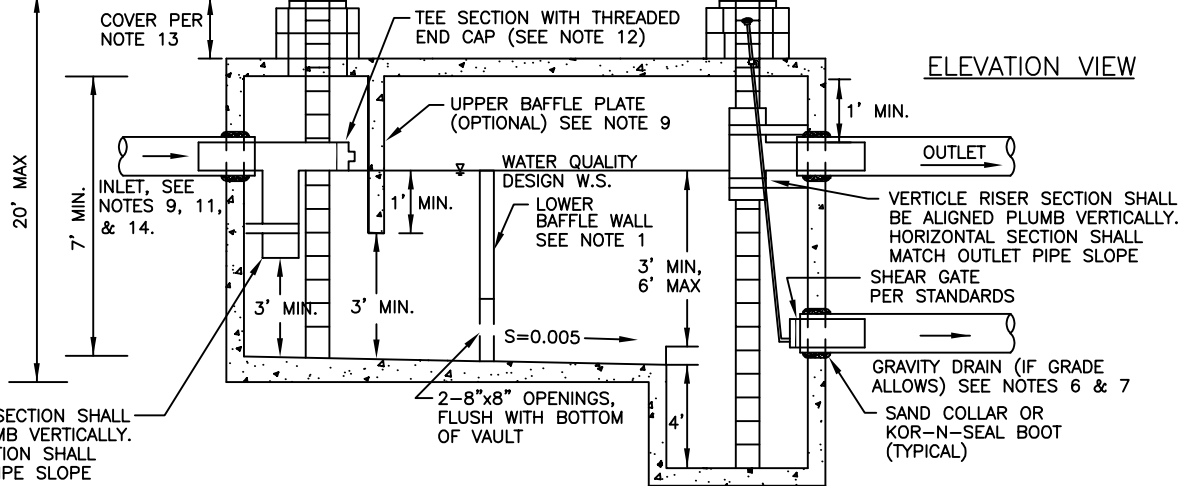

VERTICLE RISER SECTION SHALL BE ALIGNED PLUMB VERTICALLY. HORIZONTAL SECTION SHALL MATCH OUTLET PIPE SLOPE

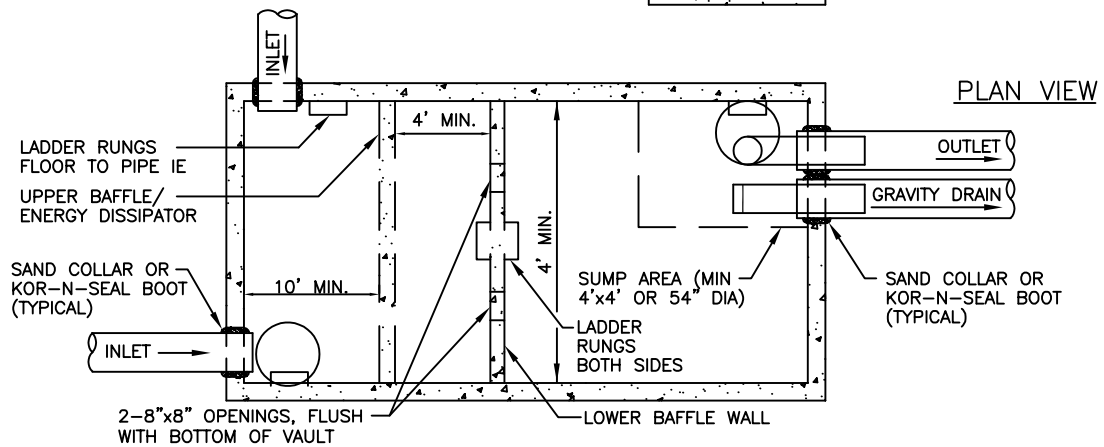

**NOTES:**

1. LOWER BAFFLE WALL TO DIVIDE VAULT INTO TWO CELLS WITH FIRST CELL (FOREBAY) TO OCCUPY 25% OF VAULT SURFACE AREA. ALL INLET PIPES MUST DISCHARGE TO FOREBAY.
2. MINIMUM ONE ACCESS MANHOLE PER CELL WITH AT LEAST ONE ACCESS PER 50' OF VAULT LENGTH OR WIDTH.
3. PRE-CAST VAULTS SHALL HAVE APPROVED RUBBER GASKET SYSTEM.
4. VAULT SHALL BE DESIGNED AND STAMPED BY A REGISTERED STRUCTURAL ENGINEER. VAULT SHALL BE DESIGNED FOR HS-20 TRAFFIC LOADING, MIN.
5. ALL METAL PARTS SHALL BE CORROSION RESISTANT.
6. GRAVITY DRAIN SHOULD BE SIZED TO EMPTY VAULT IN 4 HOURS.
7. PUMP STANDPIPE REQUIRED IF VAULT IS NOT EQUIPPED WITH GRAVITY DRAIN. TO ENABLE VAULT TO BE DRAINED FOR MAINTENANCE OPERATIONS, ONE STANDPIPE IS REQUIRED FOR EVERY 35,000 CF OF DEAD STORAGE. SEE SUMP WITH RISER PIPE DETAIL.
8. PROVIDE LADDER RUNGS IMMEDIATELY ADJACENT TO INLET PIPES.
9. UPPER BAFFLE PLATE MAY BE USED IN LIEU OF TEE SECTION ON INLET PIPES.
10. FLOW SPLITTER/BYPASS REQUIRED UPSTREAM OF WET VAULT TO DIVERT FLOWS THAT EXCEED THE PEAK FLOW FOR THE WATER QUALITY DESIGN STORM AROUND THE WET VAULT. BYPASS STRUCTURE MUST BE EQUIPPED WITH SHUT OFF MECHANISM TO ENABLE THE VAULT TO BE TAKEN OFF LINE FOR MAINTENANCE.
11. TEES SHALL BE ORIENTED VERTICALLY WITHIN THE VAULT, REGARDLESS OF THE SLOPE OF THE INCOMING PIPE.
12. ADAPTER FOR THREADED END CAP SHALL BE SECURED TO TEE WITH SCREWS.
13. IF PROPOSED COVER IS GREATER THAN 1', THEN IT MUST BE 2.5' MINIMUM AND ACCESS MUST BE 48" ECCENTRIC CONE, SET OVER 24" DIAMETER ACCESS OPENING.
14. INVERT ELEVATION OF INLET PIPE SHALL BE PER DESIGN ENGINEER'S CALCULATIONS.
15. ALL PIPES SHALL BE PERPENDICULAR TO FACE OF VAULT.
16. APPLY NON-SHRINK GROUT TO INSIDE AND OUTSIDE OF ALL JOINTS, RINGS, RISERS AND FRAMES.
17. PENETRATE CARRIER PIPE THROUGH VAULT WALL.
18. USE APPROVED WATERTIGHT STRUCTURE ADAPTOR.
19. SLIP SMOOTH-BORE HORIZONTAL LEG OF FLOW CONTROL TEE INSIDE CARRIER PIPE.
20. NO FLOW CONTROL JOINT OUTSIDE OF STRUCTURE.
21. PRIOR TO STARTUP, RUNOFF TREATMENT VAULT (WET VAULT) SHALL PASS 1% PER DAY LEAK TEST WHERE A MAXIMUM OF 1% WATER LOSS IS ALLOWED WITHIN A 24-HOUR PERIOD WITH VAULT FILLED TO 2-YEAR STORM ELEVATION. TEST PER THE UNIFORM PLUMBING CODE 712.2.



City of Bellevue

STORM AND SURFACE WATER UTILITY

TITLE

RUNOFF TREATMENT VAULT (WET VAULT)