

ELEVATION VIEW

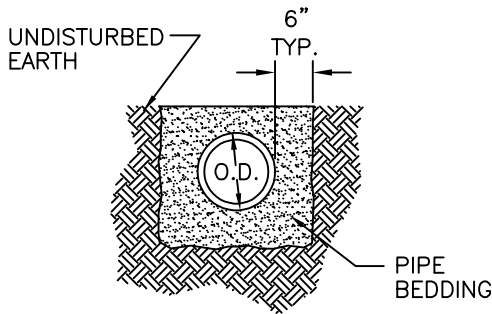

SECTION A-A

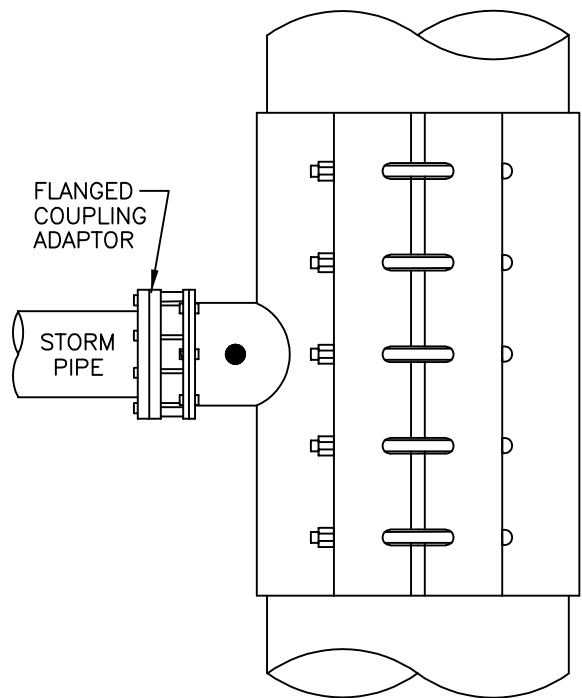

PLAN VIEW

NOTES:

1. "D", THE INSIDE DIAM. OF THE INLET PIPE, SHALL BE 8" OR LESS. FOR LARGER VALUES OF "D", USE A MANHOLE OR CATCH BASIN.
2. IN NO CASE SHALL THE OUTSIDE DIAM. OF THE INLET PIPE EXCEED ONE-HALF THE INSIDE DIAM. OF THE MAIN STORM DRAIN PIPE.
3. C. OF INLET PIPE SHALL BE ON RADIUS OF MAIN STORM DRAIN.
4. THE MIN. OPENING INTO THE EXISTING STORM DRAIN SHALL BE THE OUTSIDE DIAM. OF THE INLET PIPE PLUS 1 IN.
5. MAINLINE SHALL HAVE 12" MIN. DIAM.
6. STAINLESS STEEL TAPPING TEES SHALL HAVE FULL CIRCLE SEAL. BOLTS AND NUTS SHALL BE STAINLESS STEEL.
7. ALL TEES TO BE WATER TESTED BEFORE TAP.
8. TAPPING TEE MAY BE SIZE ON SIZE. TAP SHALL BE AT LEAST 2" SMALLER DIAMETER THAN THE EXISTING STORM MAIN.



City of Bellevue

STORM AND SURFACE WATER UTILITY

TITLE

TAPPING TEES FOR DRAIN PIPE